

Assembly Instructions

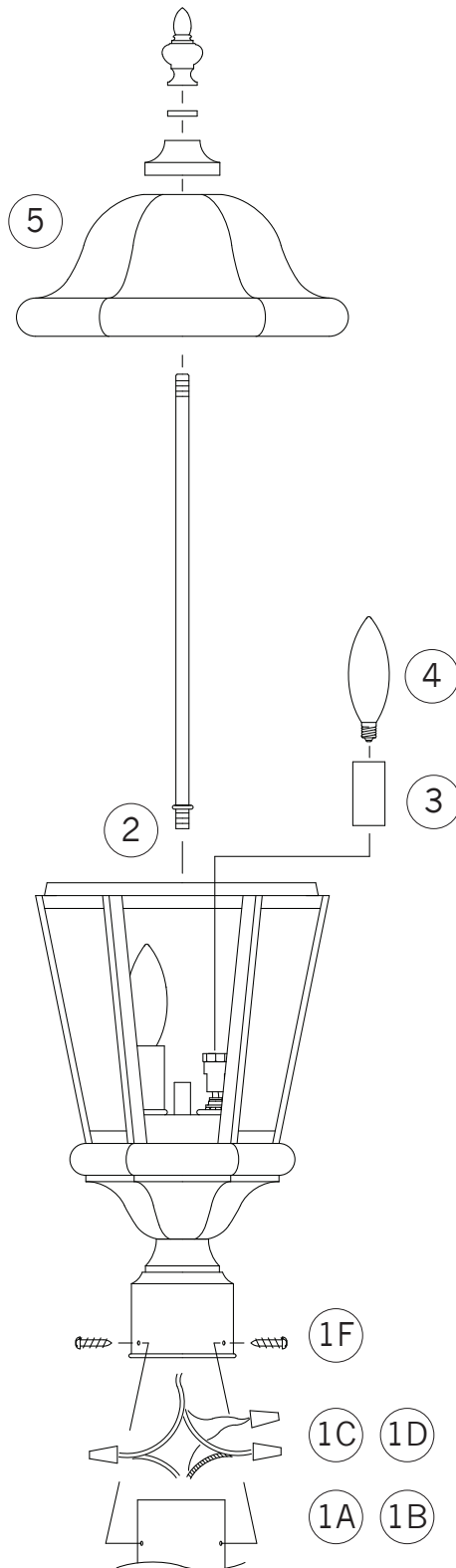

IMPORTANT TURN OFF THE POWER AT THE MAIN FUSE OR CIRCUIT BREAKER BOX BEFORE STARTING INSTALLATION

Carefully unpack and identify all parts before assembly. Bulb not included.

1. Electrical installation onto post (not supplied): If you are replacing an existing fixture, disconnect and remove the old fixture.
 - A) Slip post cup over post. Mark position of holes in post cup on post.
 - B) Remove post cup and expose the supply wiring from above post. Drill 1/8" (3mm) diameter pilot holes in post at places where marked.
 - C) Connect white fixture wire to white supply wire from post with wire connector. Connect black fixture wire to black supply wire from post with wire connector.
NOTE: Black wire from post may be red, round and smooth and/or have copper conductor. White wire from post may be square and ridged and/or have a silver conductor.
 - D) Connect fixture ground wire (without plastic insulation) to ground wire from post (usually with green insulation) with wire connector.
IMPORTANT: Never connect ground wire to black or white supply wires.
 - E) Tuck all wires inside of post.
 - F) Slip post cup onto post. Align holes in post cup with holes in post. Secure them together by fastening with sheet metal screws (enclosed).
2. Screw short threaded end of center pipe into top coupler.
3. Slip candle cover tube onto sockets.
4. Install light bulb (not included). See relamping label at socket area for type and maximum allowed wattage.
5. Slide top cover and font through center pipe until checks onto main frame. Lock them into position by fastening with rubber washer and finial.